



Roll Tarps

JOHN DEERE 50, 60, 70 series

CASE IH 8010, 7010

NEW HOLLAND CR 960 – 970, 940

OPERATOR'S AND OWNER'S MANUAL

D & F Manufacturing Ltd.

Morris, Mb

Box 121

R0G 1K0

(204) 746-8260

TABLE OF CONTENTS

1. INTRODUCTION	1
2. SAFETY	2
2.1. GENERAL SAFETY	3
2.2. PLACEMENT SAFETY	3
2.3. MAINTENANCE SAFETY	3
3. OPERATING AND SAFETY INSTRUCTIONS	4
3.1. SAFETY	4
3.2. OWNER/OPERATOR RESPONSIBILITY	4
3.3. FIRST USE	5
3.4. CONTROLS	5
3.5. STORAGE	6
3.5.1. PLACING INTO STORAGE	6
3.5.2. TAKING OUT OF STORAGE	6
3.6. SERVICING	6
3.6.1. RE-TENSIONING THE TARP	6
3.6.2. DECALS & SIGNS	6
4. ASSEMBLY	7
4.1. MACHINE COMPONENTS	7
4.2. ASSEMBLY	8
5. MODEL SPECIFIC INSTRUCTIONS	10
5.1. JD 9860, 9760, 9660, 9750	10
5.2. CASE 8010, NH 940, 960, 970, 1688, 2188, 2388	10

1. INTRODUCTION

Congratulations on your choice of a Haul-All Combine Roll-Tarp for your agricultural needs. The Combine Roll Tarp (CRT) has been designed to fit your farming and storing requirements. Safe and efficient operation of this unit, however, requires that the owner and all operators read this manual and all portions that pertain to your operation.

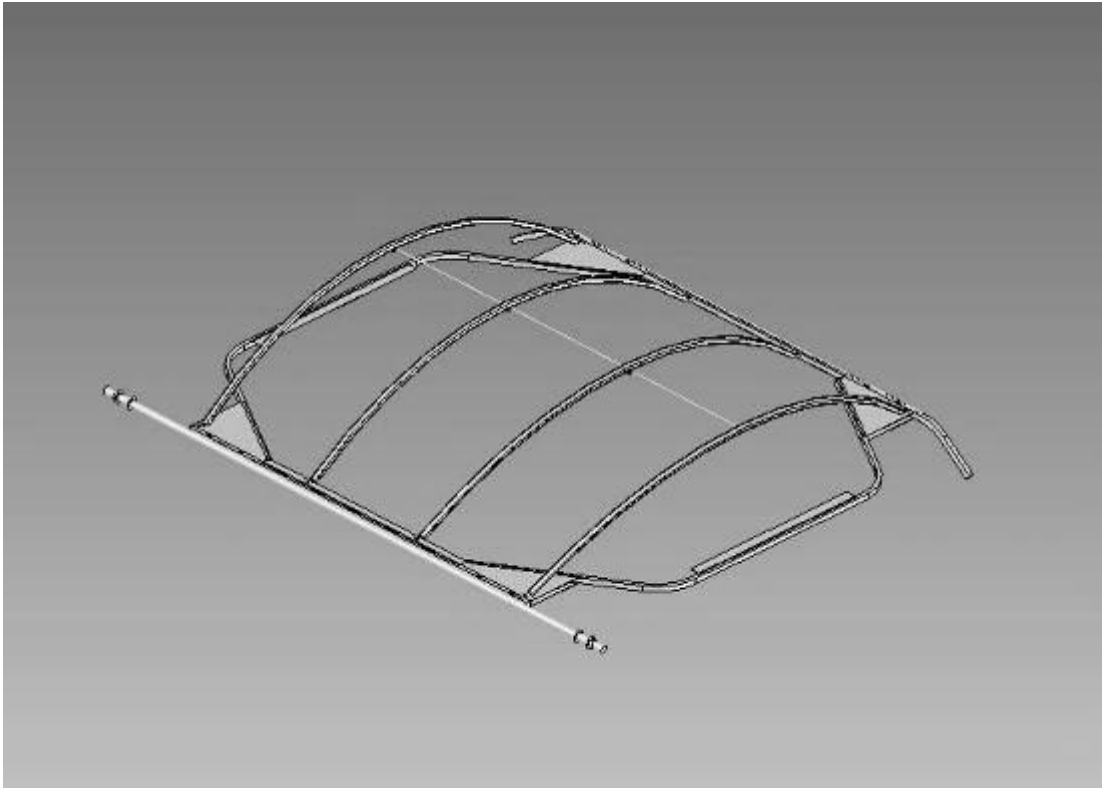

This manual covers the CRT's that fit John Deere 50, 60 and 70 series combines, Case IH 7010, 7120, 8010, 8120, and New Holland CR 960, 970, 9070 and 9080. Use the Table of Contents as a guide when searching for specific information.

Keep this manual handy for frequent reference and to pass on to new operators or owners. Call D&F Manufacturing Ltd or your CRT dealer if you need assistance, information, or additional copies of the manual.

Operator Orientation- The directions left, right, front, and rear as mentioned throughout this manual, are as seen from the combine driver's seat and facing the direction of travel when the unit is being transported.

2. SAFETY

This Safety Symbol is used
Throughout the manual to
Highlight places of danger.
Pay special attention to all
Areas that have this symbol

Accidents cost you time
Accidents cost you money
Accidents are avoidable
Accidents Disable and Kill

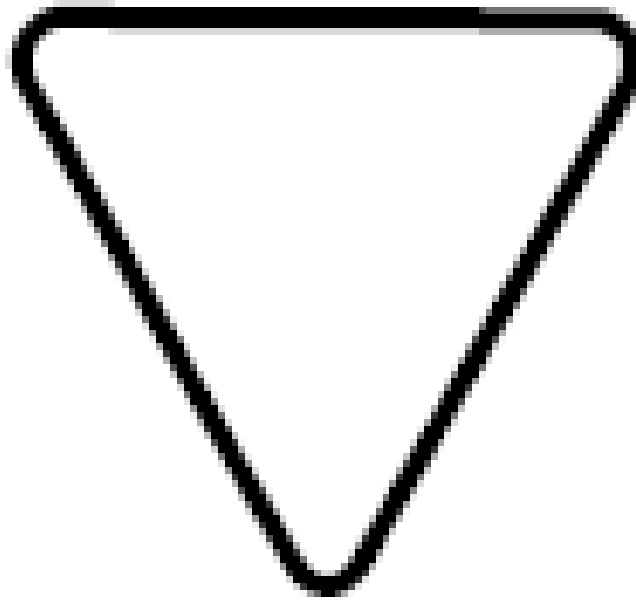

**-ALL AREAS WITH THIS SIGN ARE IMPORTANT-
READ THEM CAREFULLY**

YOU are responsible for the safe operation and maintenance of your Combine Roll Tarp. **YOU** must ensure that you and anyone else who is going to operate, maintain or work around the Roll Tarp be familiar with the operating and maintenance procedures and related **SAFETY**

information contained in this manual. Good safety practices protect you and the people around you. Most accidents can be prevented with the following precautions. Do not risk death or injury by ignoring these safety practices.

GENERAL SAFETY

1. Read and understand the Operator's Manual and all safety signs before operating, maintaining, adjusting, or installing.
2. Only trained, competent persons shall operate the CRT. An untrained operator is not qualified to operate this unit.
3. Review safety related items annually with all personnel who will be operating or maintaining the Roll Tarp.

2.2 PLACEMENT SAFETY

1. Stay away from overhead power lines when using the Roll-Tarp. Electrocuting can occur without direct contact.
2. Follow all the safety requirements in the Roll-Tarp Manual at all times.
3. Ensure that the Roll Tarp is fastened securely to the combine at all times. Do not allow traffic near the combine if it is not.



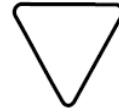

2.3 MAINTENANCE SAFETY

1. Review the Operator's Manual and all safety items before working with, maintaining, or operating the Roll-Tarp.
2. Follow good shop practices:
 - a. Keep service area clean and dry.
 - b. Be sure electrical outlets and tools are properly grounded.
 - c. Use adequate light for job at hand.
3. Clear the area of bystanders, especially children, when carrying out maintenance and repairs or making adjustments.
4. Before resuming work, install and secure all guards when maintenance is complete.
5. Keep safety signs clean. Replace signs that are damaged or not clearly visible. See Chapter 3.6.2 for more information on safety sign location.



3. OPERATING AND SAFETY INSTRUCTIONS

3.1 SAFETY

1. Read and understand the Operator's Manual and all safety signs before using.
2. Keep hands, feet, hair, and clothing away from rotating parts.
3. Do not allow riders to climb on the unit or combine when using.
4. Stay away from overhead obstructions and power lines during operation and transportation. Electrocutation can occur without direct contact. 
5. **Do not operate unit when guards are not in place.**
6. Place Roll Tarp in its closed position when not in use. If it is not locked in the closed position contaminants may enter the unit damaging equipment later.
7. If the Roll Tarp is not transported in either the fully closed or fully open and latched position it can come loose and damage equipment or persons nearby. 
8. Inspect all cables, pulleys, and the tarp before using. Replace or fix if necessary.

3.2 OWNER/OPERATOR RESPONSIBILITY

The Haul-All Roll Tarp is designed for the extending of your combine's storage and for protection of your crop in the field. Be familiar with the unit before starting.

It is the responsibility of the owner or operator to read this manual and to train all other operators before they start working with the unit. In addition to the design and configuration of equipment, hazard control, and accident prevention are dependent upon awareness, concern, and prudence of personnel involved in operation, transport, maintenance, and storage of equipment or in the use of maintenance facilities.

Follow all safety instructions exactly. Safety is everyone's business. By following recommended procedures, a safe working environment is provided for the operator, bystanders, and the area around the work site. Untrained operators are not qualified to operate the machine.

D&F Manufacturing Ltd assumes no responsibility for damages to the unit or persons due to improper procedures used during assembly or improper attachment of the unit to the combine. Follow all safety instructions and use caution when handling the unit.

FIRST USE

Although there are no operational restrictions on the Roll Tarp for the first use, it is recommended that the following items be checked:

1. Before Starting:
 - a. During the first few minutes of use, ensure that all cables and springs are working properly and do not vary under load conditions. See Chapter 3.6.1 for servicing instructions.
 - b. Ensure that the tarp travels evenly and tightly across supports.
2. After operating or transporting for 5 to 10 hours, check these things. Also check them annually:
 - a. Re-torque all the fasteners and hardware.
 - b. Check that all safety decals are installed and legible. Apply new decals if required.
 - c. Check the spring tension and make sure that the cables cannot skip on the cylindrical Cable Spool. Check tension on tarp cables and re-tension if necessary. See Chapter 3.6.1.
 - d. Check that all guards are installed and working properly. 
 - e. Ensure the tarp is set and locked in place.

3.4 CONTROLS

1. The handle is used to roll and unroll the tarp and to lock the tarp in place when not in use.
2. **Do not use the tarp if the Tarp Clamps are not in place. The tarp may become detached and become a falling hazard.** 
3. Lock the handle in the crank handle holder when you are not adjusting the tarp. This prevents the tarp from rolling up poorly or shifting dangerously.

3.5 STORAGE

3.5.1 Placing Into Storage

1. Store with the unit either collapsed with the tarp roller up or on the combine with the tarp locked in the closed position
2. Make sure the tarp is not damaged or torn when placing in storage to prevent mildew or further problems from developing.
3. Store the unit away from human activity.
4. Do not permit children to play on or around the stored Roll Tarp.
5. Remove all residual material from in and around the Roll Tarp.
6. Wash the machine thoroughly using a hose or pressure washer to remove all dirt, mud, debris, seed, and water.
7. Touch up all paint nicks and scratches to prevent rusting. For touch-up color matching, consult your local CRT distributor.

3.5.2 Taking Out of Storage

1. Replace any damaged parts and safety decals.
2. Inspect tarp. Add tension to cables if required. See Chapter 3.6.1.
3. Check for nicks or scratches in paint. Touch up to prevent rust.

3.6 SERVICING

3.6.1 Re-Tensioning the Tarp

This must be done after a week of placing the tarp on the combine to allow the canvas to relax into its final length.

1. Lock tarp completely closed in its holding latch.
2. If handle is not firmly tight the tarp is too loose and may come undone during use and/or transportation.
3. Place the roll tube into the final closed position (see picture 4) and loosen the bolts attaching the tarp clamps on the front bar of the tarp frame.
4. Roll up some more canvas on the small roll tube until the desired tension is achieved on the canvas. (see step 7 in Assembly section)
5. Roll tarp closed again and latch the handle into place to test tension. Repeat if necessary.

3.6.2 Decals & Signs

1. Replacement decals and labels are available from your local CRT distributor.
2. Be sure that the installation area is clean and dry.
3. Decide on the exact position before you remove the backing paper.
4. Align the sign over the specified area and carefully press the small portion with the exposed sticky backing into place.
5. Slowly peel back the remaining paper and carefully smooth the remaining portion of the sign in place.
6. Small air pockets can be pierced with a pin and smoothed out using the piece of sign backing paper

4. ASSEMBLY

4.1 MACHINE COMPONENTS

The Combine Roll Tarp is composed of a steel frame designed to fold down to minimize storage space when not in use. With a few easy steps, the Roll Tarp expands to form a rain and wind proof and cover that eliminates blow-off, prevents

spoilage, and removes the necessity to rush off the field in summer storms. The telescopic crank handle allows you to open and close your tarp without leaving the safety of the ground.

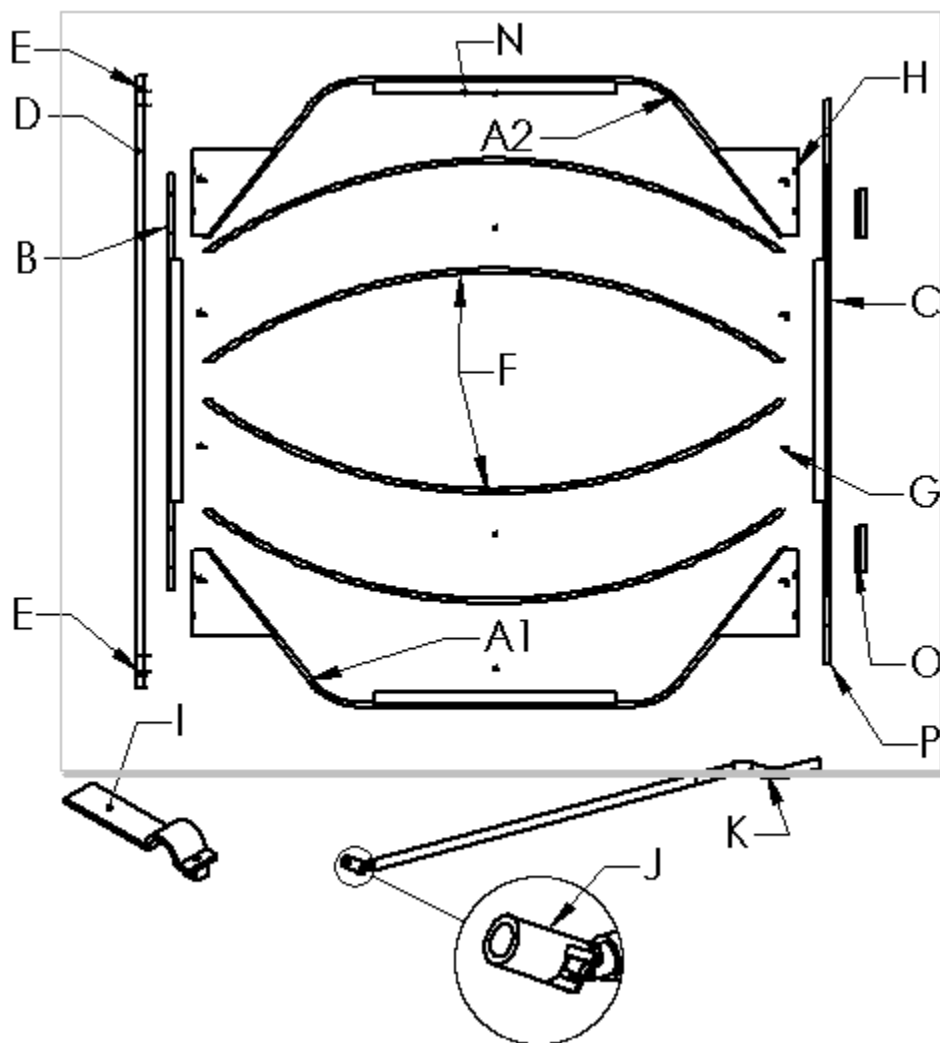

4.2 ASSEMBLY

1. Insert the front and rear sections (B & C) between the plates of the fenders (A1 & A2) being sure that the rear section (C - longer of the two) and the Flat Tarp Rests (O) are fastened with the same 5/16" bolts. **Be sure to place the Tarp Rests on the bottom angled down (see photo 1).**
2. Connect the bows (F) to pegs (G) located on the front and rear sections (B & C).
3. Join the bows (F) together with the straps and clips being careful to tighten them evenly to keep the bows in the upright position.
4. Center the tarp on the frame and unroll it halfway.
5. Using the Tarp Clamps (I) and 5/16" X 1-1/2" bolts fasten the smaller of the two Tarp Pipes to the front of the frame **loosely** (more adjustment is required before it is tightened firmly).
6. Slide the cable spools (E) onto each end of the larger Tarp Pipe (D) and center each spool with the end of the horns on the rear section (C). The Cable Pinch Groove on both spools should be oriented similarly (either to the inside or outside).
7. Unroll the tarp completely, covering the unit, and verify that the pipe (D) sits in the Tarp Rests properly. It is designed to sit **on** the Tarp Rest and under the 3/8" round rods. **If the tarp is too long and falls below the Tarp Rests, loosen the Tarp Clamps (I) at the front section and roll more tarp onto the smaller Tarp Pipe until the Larger Tarp Pipe (D) rests properly on top of the rests.**
8. Feed the loop end of one of the cables into one end of the Horn Tube (C) until it comes out of the other side. Attach the two springs in succession and then to the other cable end loop.



9. Pull the entire spring & cable assembly into the horn and pound the Grey Cable Guides into each end.
10. Roll the tarp completely up with your hands and wrap one cable around its spool about two times by passing the cable **underneath** the spool first.
11. Repeat for the other cable by stretching the springs and wrapping the cable the **same amount** on the other spool.
12. Roll tarp back up. As you do, the spring will loosen; wrap cable around spool as needed to maintain tension. If cable is too tight at the end, release Cable one wrap at a time.
13. Lift the entire unit onto the combine. Position so that the tube frame of the Roll Tarp rests outside the perimeter of the hopper extension. **The tube with the springs in it is the rear panel (C).**
14. Bolt the tarp frame to the combine extension using 5/16" self-threading bolts. Two bolts thread into the front and rear panels and one into each side. **Pre-drill a 1/4" pilot hole first.**
15. Bolt the A-frame crank handle holder bracket to the flange on the front of the clean grain elevator. Drill two holes and use the 3/8" x 1.5" bolts provided.
16. Connect the Crank Arm (M) to the U-joint (J) so that the crank does not interfere with access panels while in operation.
17. Roll the tarp open and closed several times to ensure that the cables are tensioned properly and evenly and that the tarp fits well. Several days in the sun may cause the tarp to become more relaxed and it might require re-tensioning. Readjust the Tarp Clamps and springs if necessary.

